

TYPICAL PATHWAY CROSS SECTION

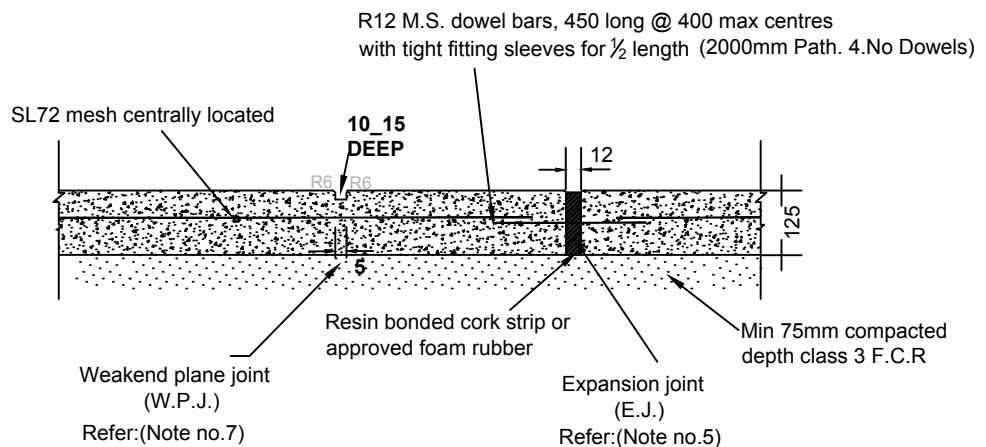

PATHWAY JOINT DETAILS

Notes:

1. Remove all organic material, level and compact subgrade before placing FCR bedding.
2. Concrete strength to be 25 Mpa for all paths.
3. Concrete footpath/ shared bicycle path shall be reinforced with SL72 mesh placed centrally on bar chairs @ 1m c/s in both directions.
4. Footpath at Vehicle crossings refer drawing number SD 003/004.
5. Provide expansion joints at 15 m c/c spacings.
6. Concrete to be natural colour (grey) with non-slip light broom finish(transverse direction).
7. Footpath bay length shall be equally spaced @1500mm.
8. All joints to be straight, perpendicular, neat and smooth finish with no arises.
9. Crossfall to be 1 in 40 (50mm for a width of 2.0 m).
10. Max longitudinal grade for all paths shall to be 1 in 14. Grades in excess of 1 in 14 require council & DDA approval.
11. Nature strips and disturbed areas are to be reinstated with 100mm depth of approved topsoil and select grass seed.



CONCRETE PATHWAY PARKS AND RESERVES 2.0m WIDE (Not To Scale)

DRAWN BY: C.B

CHECKED : L.T.

DATE: 14.08.17

SD 006

REVISION	DATE	APPROVED
2.	15.11.2011	C.B.
3.	05.04.2013	L.T.
4.	14.08.2017	D.G.