

CONSTRUCTION JOINT(OPTIONAL)

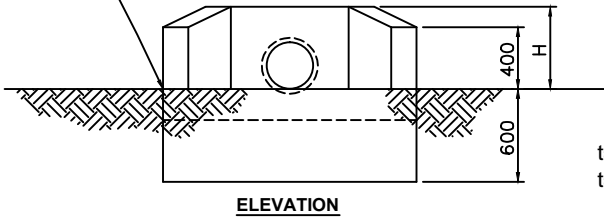

ELEVATION

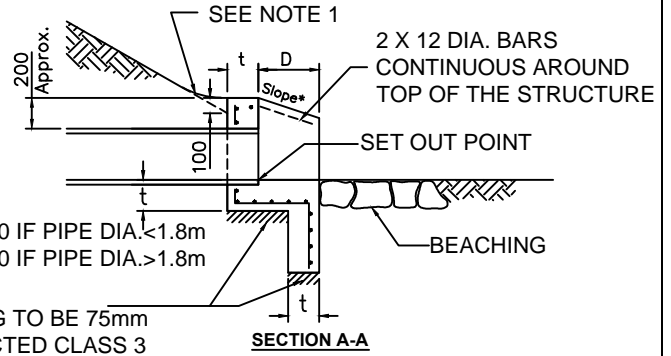

BEDDING TO BE 75mm
COMPACTED CLASS 3
CRUSHED ROCK

SECTION A-A

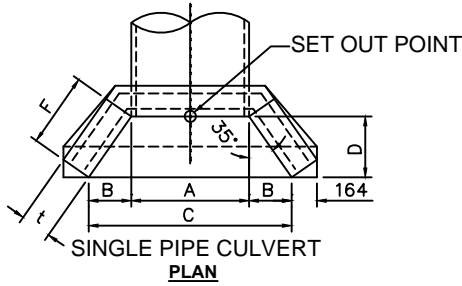

SINGLE PIPE CULVERT
PLAN

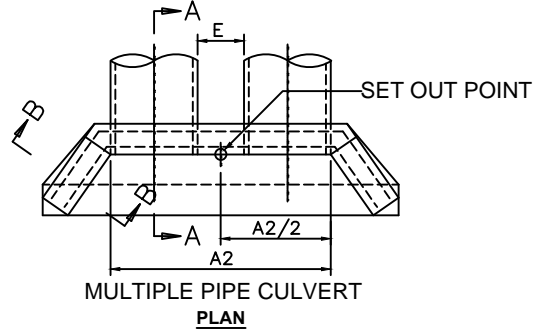

MULTIPLE PIPE CULVERT
PLAN

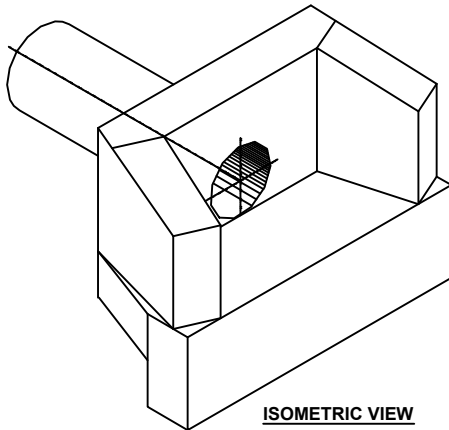

ISOMETRIC VIEW

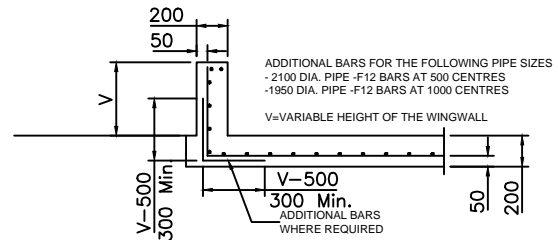

SECTION B-B

DIMENSIONS																
NOM. PIPE DIA.	EXTER. PIPE DIA.#	A**	E	H	TYPE 1 *SLOPE AT 1.5:1				TYPE 2 *SLOPE AT 2:1				TYPE 3 *SLOPE AT 3:1			
					B	C	D	F	B	C	D	F	B	C	D	F
600	698	698	300	854	477	1652	681	831	636	1970	908	1108	954	2605	1362	1663
675	781	781	340	935	560	1901	800	976	746	2274	1066	1301	1120	3020	1599	1952
750	864	864	375	1013	644	2152	920	1123	858	2581	1226	1497	1288	3439	1839	2245
825	946	946	410	1092	727	2400	1038	1267	969	2884	1384	1690	1454	3853	2076	2534
900	1029	1029	450	1172	811	2651	1158	1414	1081	3191	1544	1885	1622	4272	2316	2827
1050	1194	1194	525	1330	977	3148	1395	1703	1302	3799	1860	2271	1954	5101	2790	3406
1200	1359	1359	600	1489	1144	3647	1634	1994	1525	4409	2178	2659	2288	5934	3267	3988
1350	1524	1524	675	1648	1311	4146	1872	2285	1748	5019	2496	3047	2622	6767	3744	4571
1500	1676	1676	750	1800	1470	4617	2100	2564	1961	5597	2800	3418	2941	7558	4200	5127
1650	1842	1842	825	1959	1637	5117	2339	2855	2183	6208	3118	3806	3275	8392	4677	5710
1800	2006	2006	900	2117	1803	5613	2576	3144	2405	6815	3434	4192	3607	9220	5151	6288
1950	2198	2198	900	2296	1991	6181	2844	3472	2655	7508	3792	4629	3983	10164	5688	6944
2100	2388	2388	900	2474	2178	6745	3111	3798	2904	8197	4148	5064	4357	11101	6222	7596

*THEORETICAL SLOPE OF WINGWALL MEASURED AT RIGHT ANGLES TO THE ROADWAY

** A2=A+E+EXTERNAL DIAMETER OF PIPE

#APPROXIMATE ONLY

- BECAUSE THE RELATION OF BATTER TO THE TOP OF THE ENDWALL IS ESSENTIAL FOR THE SAFETY OF THE MOTORIST THE DETAILS AS SHOWN IN SECTION A-A MUST BE ADHERED TO DURING CONSTRUCTION
- REINFORCEMENT, SL82 UNLESS OTHERWISE SPECIFIED, SHALL BE CONTINUOUS AROUND CORNERS AND LOCATED AS SHOWN ON SECTIONS A-A AND B-B. CLEAR COVER 50mm MIN. LAPS/FABRICS 300MIN. BARS 25 X (BAR DIA) MIN
- DISTRIBUTION BARS 12mm DIA. AT 200mm CENTRES
- ADDITIONAL FOR LARGEST CULVERTS ARE PLACED ADJACENT TO THE MESH
- CONCRETE STRENGTH 30Mpa
- EXPOSED EDGES SHALL HAVE 20 X 20mm CHAMFERS
- COMPACTION PRESSURE BEHIND WALLS NOT TO EXCEED 15Mpa (1.5 TONNE VIBRATORY ROLLER OR 300 Kg VIBRATING PLATE)



Macedon Ranges
Shire Council

REINFORCED CONCRETE WINGWALL TYPES 1, 2 & 3

Pipe Culvert 600mm to 2100mm dia
(Not To Scale)

DRAWN BY:
C.B.

CHECKED : L.T

DATE:
05.04.13

SD 031

REVISION	DATE	APPROVED
1.	10.6.2008	J.G.
2.	5.04.2013	L.T.
3.		